

USDA Forest Service

Rocky Mountain Forest and
Range Experiment Station

Modifications of the Portable Rocket-Net Capture System to Improve Performance

Teryl G. Grubb¹

A new propellant source necessitated further testing of the rocket-net system and adjustment of the recommended charge pattern to 25-20-25 pellets for the large (9.9 x 14.1 m) 3-rocket net. Consistency of both the large and small (7.5 x 7.5 m, 2-rocket) systems was improved by converting all draglines to shock cord, replacing free drag weights with anchor stakes, and leveling the net-boxes. Current configurations yield 51% and 58% of maximum spread for the large and small nets, respectively. During wintering bald eagle (*Haliaeetus leucocephalus*) research, 14 of 19 shots (74%) successfully captured 20 of 31 eagles (59%) for an average catch of 1.1 eagles per shot.

Keywords: Net, rocket, wildlife capture, trapping, bald eagle, *Haliaeetus leucocephalus*

Management Implications

Construction, initial testing, and field application of the portable rocket-net capture system have been described previously (Grubb 1988). However, changes in propellant loads and drag configuration, along with minor modifications of net shrouds and box positioning, have improved deployment consistency and negated the effect of variable substrate. With these improvements, the portable rocket-net will be lighter to transport, easier to fold, and more effective for wildlife capture. In addition, test results and associated recommendations are intended to facilitate further refinement of this technique. In the field, portable rocket-nets are best suited for situations targeting multiple animals, requiring large bait species or areas, and benefiting from capture-system portability.

Introduction

Continuing field experience with the 2- and 3-rocket net systems (fig. 1) on wintering bald eagles in north-

¹Research Wildlife Biologist, Rocky Mountain Forest and Range Experiment Station, Research Work Unit at Tempe, in cooperation with Arizona State University. Station headquarters is in Fort Collins, in cooperation with Colorado State University.

central Arizona (Grubb et al. 1989) has led to several modifications of the original design (Grubb 1988). A new source for commercial propellant in 1988 also necessitated further test firing to accommodate the apparently more powerful charges. This note describes those modifications and provides comparative test results and load recommendations for the propellant currently available.

Modifications to Materials and Construction

Nets, recoilless rockets, and propellant were originally purchased from Wildlife Materials (WMI), Carbondale, IL.² Propellant is now solely available through Winn-Star, Inc. (WSI), Marion, IL.,² which also handles comparable nets and rockets. The present cost for each 3-rocket firing is about \$12.

Nets

Inherent kinking and fouling of the nylon shroud (or lead) lines was noted in Grubb (1988); however, those

²The use of trade and company names is for the benefit of the reader; such use does not constitute an official endorsement or approval of any service or product by the U.S. Department of Agriculture to the exclusion of others that may be suitable.

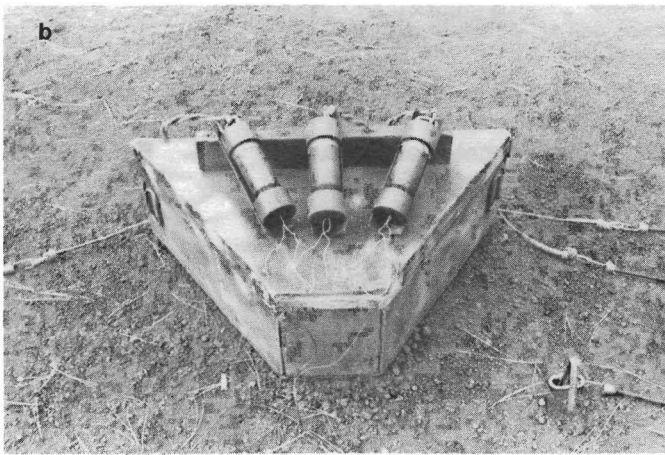
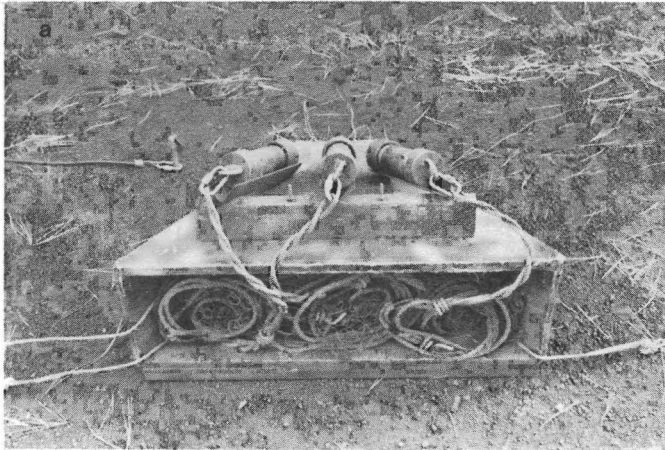

Figure 1.—Large (3-rocket), portable, rocket-net capture system as viewed from front (a) and rear (b). Note positioning of draglines and location of center anchor stake.

lines should have been described as "twisted" rather than "braided." (Standard twisted line—usually gold—consists of three multifilament strands twisted together, resulting in a barber-pole appearance. Braided nylon line—usually white—has a finely woven external appearance and is much softer and more pliable at equal strength.) Replacing the original rocket shrouds of twisted nylon with comparably sized, braided nylon generally eliminated kinking and fouling, reduced the likelihood of net entanglement during firing, and facilitated folding. Ordering nets with braided rather than twisted shroud lines would obviate this modification.

Bloom (1987) recommends 10.2- x 20.3-cm mesh for trapping eagles (with 15.2- x 15.2-m cannon nets) because smaller mesh causes the net to remain airborne too long. Slow flight is less of a problem with smaller, rocket-propelled nets. Nonetheless, a mesh larger than the 5.1 cm originally recommended and currently used may prevent the occasional eagle from walking or flapping out from under a deployed net, by facilitating some entanglement. A 10.2- x 10.2-cm mesh should solve this problem with eagles³ and can be obtained by direct ordering, or by cutting the 5.1- x 5.1-cm mesh to

³Personal communications with C. R. Gray, Wildlife Capture Specialist, CODA Enterprises, Inc., Mesa, AZ, 1989–1990.

create the larger openings. Although untested with these rocket nets, a larger mesh (and therefore lighter net) may improve the percent spread described below.

Rockets

WSI rockets were used in all 3-rocket tests because they are similar in shape and volume to the homemade rockets (described by Grubb 1988) used with the 2-rocket net (fig. 1b). Whether purchased or homemade, precise and even spacing of escape jets (or ports) on the rockets is critical to consistent flight among rockets and uniform net deployment. However, because small variation between rockets is typical, it is good practice to avoid interchanging rocket bodies and jetted end-caps, and to color code rockets to their respective shrouds with paint or tape. Joining rockets to shroud lines with 5-cm, threaded, locking links (fig. 1a) facilitates removal and attachment.

Propellant

WSI became the commercial vendor for rocket-net propellant in 1988. Charges were basically unchanged, except for being primed with a starter packet of only black powder. Because of better quality control in culling the nitrocellulose pellets and/or a different production lot supplied to WSI by the Department of Army, recent charges are more powerful than pre-1988 ones. Previously established loading patterns (Grubb 1988) cause nets to deploy higher, further, and more forcefully than expected. Despite the fact that WSI markets changes specific to the different shapes and volumes of WMI and WSI rockets, pellet counts had to be adjusted to obtain proper operation of the portable rocket-net systems. Heavier primers (18 g) from WMI-designated charges resulted in quicker, cleaner, and more powerful burns, regardless of nitrocellulose load or rocket size. All testing described below was performed with WMI-designated or 18-g primers, which are unilaterally recommended.

Rocket-Net Box

During both large and small net testing and usage, a level box yielded best results. Leveling was accomplished by raising the rear of the box with a stick, rock, or snow. Alternatively, permanent attachment of a 20.5-cm-long, 5.1- x 5.1-cm piece of wood (2 by 2) to the bottom rear of the box would facilitate leveling, while providing better footing than the other option of removing the 5.1- x 5.1-cm piece along the leading edge. Adjustable, threaded feet, as used on furniture, might also work for leveling and field adjustment.

Although untested, a smaller, lighter box specific to the 2-rocket net could be made by moving the rocket launchers to the rear edge of the box, eliminating the unused center launcher, relocating the handles and

leading-edge 5.1- x 5.1-cm piece of wood accordingly, and trimming 15–20 cm off the front of all four box surfaces.

Drags

Drag weights have been replaced by 1.3-cm angle iron, 46 cm long, bent into anchor stakes for driving into the ground (fig. 2). All nylon draglines have been replaced with 1-cm-diameter shock cord. Shock cord for these and previous tests was purchased in standard 76-cm lengths and joined by crimping the pre-attached hook fittings together. The hook on one end was left intact for attaching to loops in the shortened, nylon draglines from the net. A 5-cm, threaded, locking link was attached at the other end to provide a strong anchor point (fig. 2). The composite configuration permits easy folding and storage, as well as replacement of any damaged sections. A continuous 5-m length of shock cord may have more elasticity and cause different deployment results than those reported here. All draglines for both nets were anchored 1 m behind the leading edge of the rocket-net box; the center anchor for the 3-rocket net was placed along the right side of the box (figs. 1 and 3).

System Testing

Methods

Test firings (30 large net, 11 small net) of varying combinations of rockets (WMI, WSI), primers (WMI-designated, WSI), box position (front raised, level), and drag/dragline configuration (weights, anchored; nylon center line, shock cord) with different propellant loads led to the overall rocket-net configuration now used and recommended. WSI rockets were fired with the large net because they compared in size to the small net's home-made rockets and because of better symmetry in escape port spacing. Net boxes were leveled, and the center nylon dragline of the large net was replaced with shock cord. Drag weights were replaced with anchor stakes, all located 1 m back from the leading edge of the box.



Figure 2.—Anchor stake and dragline attachment for portable rocket-nets.

Rocket launcher elevation and angle, rocket positioning, and dragline positioning were unchanged.

After initial comparison, WMI-designated or 18-g primers were used with all charges. Testing with the large net began with prepackaged loads, followed by loads that worked previously, then various other arbitrarily selected combinations, until deployment (positioning, size, and spread) suitable for trapping was obtained. Loading patterns thus determined were then replicated to test for consistency. Charge patterns of 38–38–38, 34–30–34, 32–28–32, 32–26–32, 31–27–31, 30–26–30, 28–26–28, 27–22–27, 26–22–26, 26–21–26, 25–20–25, and 24–19–24 were tested with the 3-rocket net and patterns of 26–26 and 25–25 with the 2-rocket net.

Results of replicated testing of the final configurations were compared with previous performance to evaluate positioning (distance-to-rear and distance-to-center), size (depth and breadth), spread (depth x breadth), and consistency of net deployment. Rocket-net performance was again measured by distance (m) from (a) the rocket-net box to the rear edge of the net, (b) the box to net center, (c) the rear edge of the net to the leading edge (depth), and (d) lateral edge to lateral edge (breadth or length). Percent of maximum spread $[(\text{depth} \times \text{breadth}) / (9.9 \times 14.1) \times 100]$ for the large net, $(\text{depth} \times \text{breadth}) / (7.5 \times 7.5) \times 100$ for the small net] was calculated for mean depth and breadth. Standard deviations (SD) and percent coefficients of variation (CV. $SD/\bar{x} \times 100$) provided measures of consistency.

Results

Charge patterns of 25–20–25 and 26–26 for the large and small nets, respectively, produced the best and most consistent net deployment, and most comparable results to previous performance with old propellant (table 1). Mean positioning and depth of the large net remained unchanged, but 1 m was lost in breadth from the lighter loading. Nearly all of the area lost under the large net was caused by poor extension of breadth, while depth was essentially maximized (fig. 3a). The resulting 71.2-m² spread was 6% (8.3 m²) less than the previous average obtained with old propellant, but still provided over twice the area of coverage of the small net (fig. 3b). Anchored draglines greatly improved consistency of the large net, especially for distance-to-rear. Anchors caused the small net to position 1.6 m closer to the box than recorded previously. Small net depth was unchanged, but an increase in breadth resulted in a 32.5-m² spread, up 7% (4.0 m²) from the old configuration. Lost area was caused equally by underextended breadth and depth. Consistency was only slightly improved. Rockets landed 12.5–14.9 m (small net) and 18.3–19.5 m (large net) from the box, varying about 1–3 m less than before.

Firing Procedure

All firing procedures remain the same as originally described (Grubb 1988). A simplified technique for fold-

Table 1. —Comparison of large (9.9 x 14.4 m) and small (7.5 x 7.5 m) portable rocket-net performance between previously reported (Grubb 1988) and current configurations of propellant and drags.

	Distance to		Depth ¹ (m)	Breadth ² (m)	Spread ³ (%)
	Rear (m)	Center (m)			
Large net:					
Old propellant⁴ (34–30–34), not anchored (n = 6)					
\bar{x}	7.5	12.4	9.7	8.2	57
SD ⁵	1.2	1.0	0.6	1.2	
CV ⁶	16.0	8.0	6.0	15.0	
New propellant⁷ (25–20–25), anchored (n = 7)					
\bar{x}	7.5	12.4	9.8	7.2	51
SD	0.2	0.4	0.4	0.7	
CV	3.0	3.0	4.0	10.0	
Small net:					
Old propellant (26–26), not anchored (n = 12)					
\bar{x}	8.0	10.9	5.7	5.0	51
SD	1.1	1.3	0.5	0.3	
CV	14.0	12.0	9.0	6.0	
New propellant (26–26), anchored (n = 7)					
\bar{x}	6.4	9.3	5.7	5.7	58
SD	0.8	0.8	0.4	0.3	
CV	13.0	9.0	7.0	5.0	

¹Distance from rear edge to leading edge of net (back to front).

²Distance from lateral edge to lateral edge of net (side to side).

³(Depth x breadth)/(9.9 x 14.1) x 100—large net; (depth x breadth)/(7.5 x 7.5) x 100—small net.

⁴Pre-1988.

⁵Standard deviation.

⁶Coefficient of variation - (SD/ \bar{x} x 100).

⁷1988 to present.

ing the small, 2-rocket net (adapted from the CODA Net-launcher^{2,3}) is described in appendix 1.

Winter Bald Eagle Trapping

During research on wintering bald eagles (*Haliaeetus leucocephalus*) in Arizona (Grubb et al. 1989), rocket-nets have been fired 19 times over 34 eagles since 1983. Fourteen shots (74%) captured 20 eagles (59%) for an average catch of 1.1 eagles per shot. Only 3 of the missed eagles escaped from under a net after it was on the ground. Most eagles were caught away from the box, i.e. in front of the bait, which was placed approximately half way between the expected rear edge and center of the net (10.0 m large net, 7.9 m small net, fig. 3). Those eagles that escaped the net while it was still in the air typically did so laterally. Both net systems have proven successful in capturing multiple bald eagles. Birds caught in the small net were typically closer to the bait than eagles caught with the large net.

Discussion

Whereas the configurations described yield improved performance, both rocket-net systems will benefit from continued testing and refinement. The exact cause-and-effect relationship between the new propellant/anchored dragline configuration and resultant differential perform-

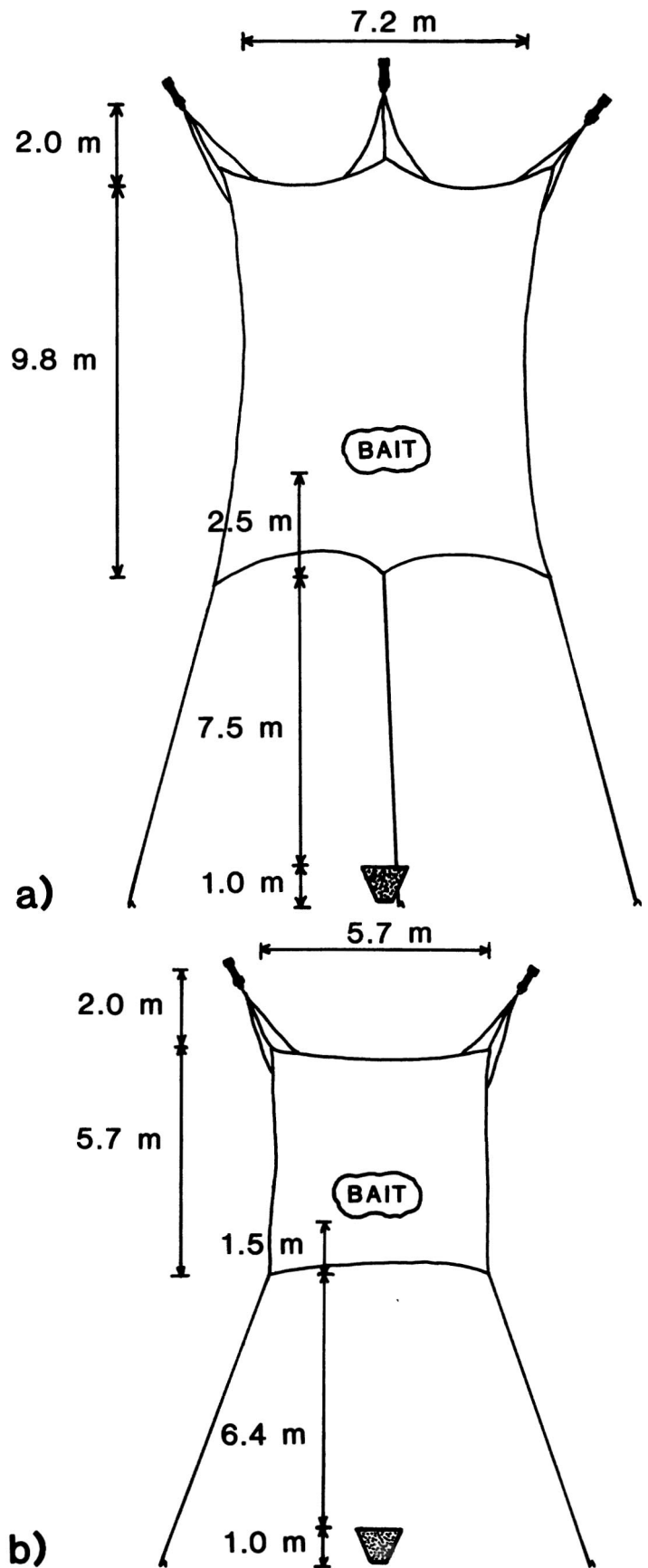

Figure 3. —Comparative deployments of the large (a) and small (b) rocket-net systems.

ances of the large and small nets is not clearly understood. However, propellant seems to most influence resultant net size and percent spread, while anchoring most affects consistency. Both factors seem to equally affect position. The only fully extended dimension with either net was large-net depth. Perhaps breadth could be improved with lighter nets (larger mesh) and/or by spreading the lateral (outside) rocket launchers on the net boxes. Further experimentation with load patterns in the small net is also warranted.

Improved consistency in positioning, size, and spread increases the likelihood of trapping success and reduces the possibility of injury. Despite the relatively low 51–58% spread, the rocket-net system is an excellent technique for providing comparatively large area coverage (necessary for trapping multiple birds with a large ungulate carcass) from a single point source that is portable and quickly set up. While the portable rocket-net success rate is competitive with most other eagle trapping systems (pers. obs., Bloom 1987), it has the inherent limitation of any "thrown" or projected net-type system where time and distance separate the target from the trap. Increasing the percent spread will mitigate the effects of these two factors by facilitating capture further from the bait.

A commercially available alternative to the portable rocket-net is the CODA Net-launcher.² It is very similar in configuration but is lighter, smaller, and safer because it uses a blank cartridge to launch 4 small, steel projectiles in cannon-net fashion. A variety of net sizes and meshes are available. Initial testing of the net-launcher, with an 8.1- x 8.1-m net for eagle trapping, resulted in size variability and loss of breadth similar

to that experienced with rocket-nets. However, later results evidenced potential for more consistent deployment, with greater than 70% spread. Deployment time for the net-launcher was comparable to the rocket-nets.

Acknowledgments

D. A. Aitkin, J. K. Aitkin, X. J. Hernandez, and M. L. Nixon provided invaluable assistance during testing and field application of both rocket-net systems. C. R. Gray and W. W. Bowerman, IV, offered instruction and access, respectively, to a net-launcher system for comparative evaluation. W. M. Block, L. A. Forbis, and J. L. Ganey furnished helpful reviews of the original manuscript.

Literature Cited

- Bloom, P. H. 1987. Capturing and handling raptors. In: Giron Pendleton, B. A.; Milsap, B. A.; Cline, K. W.; Bird, D. M., eds. *Raptor management techniques manual*. Washington, DC: National Wildlife Federation: 99–123.
- Grubb, T. G. 1988. A portable rocket-net system for capturing wildlife. Res. Note RM-484. Fort Collins, CO: U.S. Department of Agriculture, Forest Service, Rocky Mountain Forest and Range Experiment Station. 8 p.
- Grubb, T. G.; Nagiller, S. J.; Eakle, W. L.; Goodwin, G. A. 1989. Winter roosting patterns of bald eagles (*Haliaeetus leucocephalus*) in north-central Arizona. *Southwestern Naturalist*. 34(4): 453–459.

Appendix 1. Simplified procedure for folding small (7.5 x 7.5 m) rocket-net.

1. Stretch net fully; dry before folding.
2. Remove any visible debris.
3. Unravel twists in rocket shroud lines and straighten as much as possible.
4. Stand at left rear corner of net, hold corner in left hand with extended arm, extend right arm along rear edge of net, and gather rear edge of net to left hand.
5. Holding gathered rear edge line in left hand, repeat step 4 until right rear corner of net is in hand. (Steps 4 and 5 can also be executed from right to left.)
6. Keep left and right draglines properly oriented and separated.
7. Clean any debris from box and stand it on end, bottom facing net.
8. Lay gathered rear of net in box.
9. Make sure draglines go all the way to bottom of upright box. Feed left line out what will be lower left corner when box is properly positioned, and right line out lower right.
10. Standing behind the box, reach forward, rest lateral edge lines in each palm, gather equal amounts of net with fingers working toward midline, and draw net into box.
11. Occasionally and independently, pull extra net from the center into the box, thus keeping the leading edge of the net relatively straight.
12. Repeat steps 10 and 11, layering each subsequent draw on top of previous one. Lateral edge lines should be "snaking" in along sides of box.
13. When net is almost in box, make sure rocket shroud lines are properly oriented and separated.
14. Coil or layer shrouds separately on top of net.



Rocky
Mountains

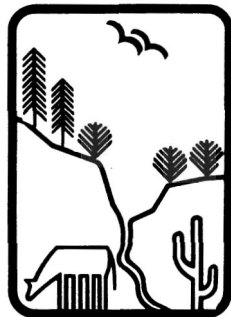

Southwest



Great
Plains

**U.S. Department of Agriculture
Forest Service**

**Rocky Mountain Forest and
Range Experiment Station**

The Rocky Mountain Station is one of eight regional experiment stations, plus the Forest Products Laboratory and the Washington Office Staff, that make up the Forest Service research organization.

RESEARCH FOCUS

Research programs at the Rocky Mountain Station are coordinated with area universities and with other institutions. Many studies are conducted on a cooperative basis to accelerate solutions to problems involving range, water, wildlife and fish habitat, human and community development, timber, recreation, protection, and multiresource evaluation.

RESEARCH LOCATIONS

Research Work Units of the Rocky Mountain Station are operated in cooperation with universities in the following cities:

Albuquerque, New Mexico
Flagstaff, Arizona
Fort Collins, Colorado*
Laramie, Wyoming
Lincoln, Nebraska
Rapid City, South Dakota
Tempe, Arizona

***Station Headquarters: 240 W. Prospect Rd., Fort Collins, CO 80526**